

Axial fans

With an external impeller and crescent-shaped aluminium blades. The fans are «step» controlled and therefore only some of them are stopped when the ambient temperature decreases. The ventilators can also be fitted with a continuous control system on request comprising a device that continuously varies the speed of rotation of all the fans.

Centrifugal fans

They comprise a circular impeller with a set of blades arranged around it. The external motor is connected to the impeller by belts and pulleys. The fans are «step» controlled. Centrifugal fans are only available for version «C».



pCO² control unit

This micro processor controlled unit features an 80 character display and 14 buttons with LED's. The unit controls the temperature of the water, the fans and the pressure of the coolant circuit, etc. It can handle up to 22 different alarm conditions. Various remote control solutions are available, ranging from a simple ON-OFF switch to the more complete BMS systems. If the ambient temperature exceeds the limit, an «unloading» system will trip and step down the chiller capacity in order to prevent the machine from blocking. Any one of five languages (Italian, English, French, German, Spanish) can be selected to visualise the alarms log and manage the pump in the stand-by mode.

Condensers

Made up of two finned pack coils in copper tubes and aluminium fins. It is generously sized in order to work at high ambient temperatures. Protective coating on request.

Heat recovery

A braze-welded stainless steel plate heat recuperator can be fitted on request. This heat recovery is also available with pressure valves on request.

Evaporator

The shell and tube evaporator features copper tubes and a carbon steel shell. The tubes are internally finned to improve evaporator performance. The tubes are «U» bent to reduce size to a minimum. It is protected by a differential water pressure switch and an antifreeze probe. It may be protected by an ambient thermostat and heating elements on request. CE and UDT testing is available.

Metal filters for condenser

Aluminium filters with galvanised sheet metal frames to protect the surface of the condenser can be supplied on request. They are easy to remove and to clean and feature an extremely high empty/full ratio.

Casing

This is made with galvanised carbon steel panels, subjected to phosphodegreasing treatment and painted with polyester powders.

Cooling circuit

- Two independent cooling circuits.
- Thermostatic expansion valves with external compensation.
- High and low pressure transducers.
- Inspectable dehydrator filter.
- Flow indicators.
- Solenoid valve on the liquid line.
- Heat recovery

Compressors

The fully-hermetic SCROLL compressors are cooled by the sucked refrigerant gas and are protected by an electronic device that controls the temperature of the winding. Suction and discharge pressures are also controlled. Circuit breakers are also available on request. These compressors have an extremely high energy efficiency (COP) and very low noise and vibration levels.

Easy user friendly

The TAURUS chillers are commanded by a microprocessor-controlled unit programmed to optimise compressor and fans, and to make sure both the coolant and hydraulic circuits work efficiently. The digital display allows the chilled water temperature to be monitored at a glance, and provides information on all operating parameters. The chiller can also be remote-controlled or connected to BMS systems on request.

Simple to install and service

To install the chiller, simply connect it to the mains power and water supplies. No other operations on the machine are required. The components have been specially arranged for ease of access in order to simplify both routine and extraordinary maintenance operations.

Ecological

Because it uses HFC R407c as its primary refrigerant that doesn't damage the ozone layer. Because it saves energy thanks to the highly efficient Scroll compressors. Because a chilled water air-conditioning system doesn't require primary refrigerant in rooms where people live and work. Because it has been designed and produced in accordance with the MTA Environmental Management System which complies with ISO 14001 standards.

| | | model | TA | 068 | 080 | 089 | 102 | 131 | 155 | 192 | 221 | 252 | |
|-----------------------|-----------------------|---------------------------------------|----------------------|------|------|------|------|------|------|-------|-------|-------|-------|
| R407C | Versione C | cooling capacity (1) | kW | 68.4 | 80.6 | 90.0 | 103 | 131 | 155 | 191.2 | 223.1 | 251.5 | |
| | | absorbed power (2) | kW | 19.9 | 24.1 | 29.5 | 39.2 | 41.7 | 50.7 | 57.4 | 66.2 | 73 | |
| | | max ambient temp. (3) | °C | 45 | 45 | 43 | 42 | 44 | 44 | 43 | 43 | 44 | |
| | | noise level with axial fans (4) | dB(A) | 54.9 | 54.9 | 54.9 | 55.4 | 56.6 | 56.5 | 63.2 | 64.4 | 63.7 | |
| | | noise level with centrifugal fans (4) | dB(A) | 65.2 | 65.2 | 65.2 | 65.2 | 67 | 67 | 67 | 68.2 | 74.2 | |
| | | depth (5) | L mm | 2700 | 2700 | 2950 | 2950 | 3995 | 3995 | 3995 | 4900 | 4900 | |
| | | weight with axial fans (8) | kg | 900 | 950 | 1150 | 1200 | 1430 | 1550 | 1675 | 1900 | 2100 | |
| | | weight with centrifugal fans (8) | kg | 1020 | 1040 | 1270 | 1320 | 1610 | 1830 | 1855 | 2140 | 2340 | |
| | Versione SC | cooling capacity (1) | kW | 64.3 | 77.3 | 85.1 | 97.0 | 125 | 148 | 183.5 | 213.1 | 241.9 | |
| | | absorbed power (2) | kW | 21.6 | 25.5 | 32.1 | 42.8 | 45.2 | 54.5 | 61.2 | 70.5 | 77.3 | |
| | | max ambient temp. (3) | °C | 42 | 42 | 40 | 39 | 41 | 40 | 41 | 40 | 40 | |
| | | noise level (4) | dB(A) | 48.4 | 48.4 | 48.4 | 48.9 | 50.1 | 50.0 | 56.2 | 58 | 56.7 | |
| | | depth (5) | L mm | 2700 | 2700 | 2950 | 2950 | 3995 | 3995 | 3995 | 4900 | 4900 | |
| | | weight (8) | kg | 900 | 950 | 1150 | 1200 | 1430 | 1550 | 1675 | 1900 | 2100 | |
| | | Versione SF | cooling capacity (1) | kW | 68.6 | 82.3 | 91.8 | 106 | 131 | 161 | 196.4 | 231.2 | 254.8 |
| | | | absorbed power (2) | kW | 19.5 | 23.4 | 26.5 | 37.1 | 41.0 | 48.6 | 55.1 | 62.8 | 71.8 |
| max ambient temp. (3) | °C | | 46 | 47 | 45 | 45 | 46 | 45 | 46 | 46 | 46 | | |
| noise level (4) | dB(A) | | 55.8 | 57.5 | 57.5 | 55.1 | 57.0 | 56.2 | 56.7 | 57.1 | 57.1 | | |
| depth (5) | L mm | | 2700 | 2700 | 2950 | 2950 | 3995 | 3995 | 4900 | 5805 | 5805 | | |
| weight (8) | kg | | 900 | 900 | 1150 | 1280 | 1550 | 1650 | 1850 | 2070 | 2200 | | |
| Versione SSF | cooling capacity (1) | | kW | 68.3 | 80.7 | 89.6 | 103 | 131 | 155 | 186.3 | 220.9 | 240 | |
| | absorbed power (2) | | kW | 19.7 | 24.1 | 29.6 | 38.7 | 41.9 | 50.7 | 59.9 | 67.2 | 78.1 | |
| | max ambient temp. (3) | °C | 46 | 45 | 42 | 43 | 44 | 44 | 41 | 42 | 40 | | |
| | noise level (4) | dB(A) | 48.4 | 47.7 | 47.7 | 49.1 | 50.0 | 50.9 | 50.5 | 51 | 51 | | |
| | depth (5) | L mm | 2700 | 2700 | 2950 | 3995 | 3995 | 4900 | 4900 | 5805 | 5805 | | |
| | weight (8) | kg | 900 | 930 | 1150 | 1430 | 1520 | 1650 | 1850 | 2070 | 2200 | | |

| | | model | TA | 068 | 080 | 089 | 102 | 131 | 155 | 192 | 221 | 252 | |
|-----------------------|-----------------------|---------------------------------------|----------------------|------|------|------|------|------|------|-------|-------|-------|-------|
| R22 | Versione C | cooling capacity (1) | kW | 70.1 | 84.1 | 93.1 | 106 | 136 | 162 | 197.1 | 226.7 | 257.8 | |
| | | absorbed power (2) | kW | 18.6 | 22.3 | 27.6 | 32.2 | 38.7 | 47.1 | 57.4 | 66.9 | 75.1 | |
| | | max ambient temp. (3) | °C | 48 | 49 | 46 | 47 | 48 | 47 | 46 | 46 | 46 | |
| | | noise level with axial fans (4) | dB(A) | 54.9 | 54.9 | 54.9 | 55.4 | 56.6 | 56.5 | 63.2 | 64.6 | 63.7 | |
| | | noise level with centrifugal fans (4) | dB(A) | 65.2 | 65.2 | 65.2 | 65.2 | 67 | 67 | 67 | 68.2 | 74.2 | |
| | | depth (5) | L mm | 2700 | 2700 | 2950 | 2950 | 3995 | 3995 | 3995 | 4900 | 4900 | |
| | | weight with axial fans (8) | kg | 900 | 950 | 1150 | 1200 | 1430 | 1550 | 1675 | 1900 | 2100 | |
| | | weight with centrifugal fans (8) | kg | 1020 | 1040 | 1270 | 1320 | 1610 | 1830 | 1855 | 2140 | 2340 | |
| | Versione SC | cooling capacity (1) | kW | 67.3 | 80.8 | 89.3 | 103 | 131 | 155 | 190.2 | 217.3 | 247.7 | |
| | | absorbed power (2) | kW | 20.0 | 23.7 | 29.8 | 34.3 | 41.8 | 50.6 | 61.3 | 71.5 | 80.0 | |
| | | max ambient temp. (3) | °C | 45 | 46 | 43 | 43 | 44 | 44 | 44 | 43 | 43 | |
| | | noise level (4) | dB(A) | 48.4 | 48.4 | 48.4 | 48.9 | 50.1 | 50.0 | 56.2 | 58 | 56.7 | |
| | | depth (5) | L mm | 2700 | 2700 | 2950 | 2950 | 3995 | 3995 | 3995 | 4900 | 4900 | |
| | | weight (8) | kg | 900 | 950 | 1150 | 1200 | 1430 | 1550 | 1675 | 1900 | 2100 | |
| | | Versione SF | cooling capacity (1) | kW | 71.3 | 85.4 | 95.3 | 111 | 139 | 165 | 202.2 | 234.5 | 259.8 |
| | | | absorbed power (2) | kW | 18.1 | 21.8 | 26.6 | 30.0 | 37.4 | 45.6 | 54.9 | 63.1 | 74.1 |
| max ambient temp. (3) | °C | | 50 | 50 | 49 | 49 | 49 | 49 | 49 | 49 | 48 | | |
| noise level (4) | dB(A) | | 55.8 | 57.5 | 57.5 | 55.1 | 57.0 | 56.2 | 56.7 | 57.1 | 57.1 | | |
| depth (5) | L mm | | 2700 | 2700 | 2950 | 2950 | 3995 | 3995 | 4900 | 5805 | 5805 | | |
| weight (8) | kg | | 900 | 900 | 1150 | 1280 | 1550 | 1650 | 1850 | 2070 | 2200 | | |
| Versione SSF | cooling capacity (1) | | kW | 70.1 | 83.8 | 93.2 | 109 | 137 | 162 | 191.7 | 223.7 | 246.9 | |
| | absorbed power (2) | | kW | 18.5 | 22.4 | 27.6 | 31.3 | 38.7 | 47.1 | 60.2 | 68.1 | 80.5 | |
| | max ambient temp. (3) | °C | 49 | 49 | 46 | 47 | 48 | 47 | 44 | 45 | 43 | | |
| | noise level (4) | dB(A) | 48.4 | 47.7 | 47.7 | 49.1 | 50.0 | 50.9 | 50.5 | 51 | 51 | | |
| | depth (5) | L mm | 2700 | 2700 | 2950 | 3995 | 3995 | 4900 | 4900 | 5805 | 5805 | | |
| | weight (8) | kg | 900 | 930 | 1150 | 1430 | 1520 | 1650 | 1850 | 2070 | 2200 | | |

electric supply: 400V / 3Ph / 50Hz o 460V / 3Ph / 60 Hz

| | | model | TA | 068 | 080 | 089 | 102 | 131 | 155 | 192 | 221 | 252 |
|-------------|--------------------------------|-------------------|----|------|------|------|------|------|------|------|------|------|
| tank volume | | liters | | 200 | 200 | 200 | 200 | 200 | 200 | 400 | 400 | 400 |
| pump | water flow (6) | m ³ /h | | 11.8 | 13.9 | 15.5 | 17.7 | 22.5 | 26.7 | 32.9 | 38.4 | 43.5 |
| | available head pressure P2 (7) | bar | | 1.9 | 1.5 | 2.1 | 2.1 | 1.9 | 1.8 | 1.7 | 2.2 | 2.2 |
| | available head pressure P3 (7) | bar | | 2.7 | 2.5 | 2.8 | 2.8 | 2.6 | 2.7 | 2.8 | 3.3 | 3.3 |
| | nominal power P2 | kW | | 1.8 | 1.5 | 3 | 3 | 3 | 3 | 4 | 5.5 | 5.5 |
| | nominal power P3 | kW | | 2.2 | 2.2 | 4 | 4 | 4 | 5.5 | 5.5 | 7.5 | 7.5 |

- Referred to: water outlet temperature = 7°C; delta t = 5 °C; ambient temperature = 35 °C.
- Power absorbed by the compressors in the conditions (1).
- Maximum ambient temperature refers to water outlet temperature at 7 °C.
- Sound pressure level in open field (hemispherical irradiation) on condenser side at distance of 10 m and height of 1.2 m.
- The other dimensions for all the machines are: width = 1510 mm; height = 1545 mm (height with centrifugal fans = 2100 mm)
- Referred to: water outlet temperature 7°C, delta t 5°C, ambiente temperature 35°C, refrigerant R407c.
- Available head pressure for the utilizer.
- Referred to the chiller without tank and pump.

Min. ambient temperature = -10°C for C/SC versions; 5°C for other versions.
On request, version up to -20°C ambient temperature (only for C/SC versions).

The data in this brochures are not binding. With a view to continuous product improvement, MTA reserves the right to make changes without prior notice. For further information, request the technical booklet to Sale Offices. Reproduction in whole or in part is forbidden.



Head Office & Factory
M.T.A. s.r.l.

Via dell'Artigianato, 2 - Z.I.
35026 CONSELVE (PD) ITALIA
tel. +39 049 9597211 fax +39 049 9500580
www.mta-it.com chillersales@mta-it.com



ISO 9001:2000 Cert 0572

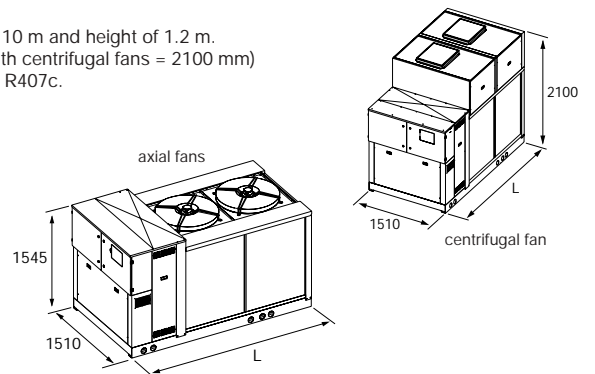

DISTRIBUTOR

Taurus

air cooled
water chillers
for
air-conditioning

cooling capacity
from 64 to 260 kW
SCROLL compressors

R407c R22
50 Hz 60 Hz



Taurus

Perfect

For commercial and domestic chilled water air-conditioning system

Constant research, experienced designers and the increasingly more qualified and diversified requirements of its customers has led MTA to produce the TAURUS range of air-cooled chillers, the perfect solution for commercial and domestic chilled water air-conditioning systems. These can be used to condition both homes and public buildings such as shopping centres, conference halls and hotels.



Complete and compact

The TAURUS water chiller is completely packaged; all the hydraulic components necessary for a chilled water air-conditioning system: tank, pump, expansion tank, air-bleed valve etc.

The external water circuit is therefore extremely simplified, allowing an easy, low cost installation.

Moreover, the configuration of the internal components has been specifically designed to give a small, compact unit.



Four versions catering for all requirements

as well as being able to choose between R407c and R22 and between 50 and 60 Hz, each model is available in 4 different versions:

- "C" basic version for normal applications
- "SC" basic version but soundproofed for reduced noise in not excessively high ambient temperatures
- "SF" soundproofed version for elevated ambient temperatures
- "SSF" extra soundproofed version for normal ambient temperatures.

Silent

The TAURUS water chillers use fans with crescent-shaped blades, specifically designed to reduce noise to a minimum together with SCROLL compressors that drastically reduce vibrations. To cater for all requirements, "step" (1) or continuously (2) controlled fans can be chosen. The noise level of the machine therefore lowers when it is most important. In the evening, the morning, and especially, at night, the ambient temperature decreases along with the noise level.

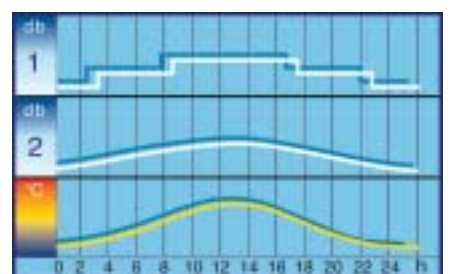



Reliability

The result of MTA technology, research and experience

Leading edge technology has been used in every aspect of the development of the TAURUS chiller. MTA Research and Development has utilised in-house design and simulation software, combined with quality components (enhanced by the choice of SCROLL compressors) and modern production techniques ensuring total reliability.

Tested

just like every MTA product or component

The TAURUS air-cooled chillers are individually tested in fully computerised state of the art cells fitted with a complete set of high precision instruments that test the machine under all working conditions, even the most extreme. The machines are all tested under rated operating conditions and temperatures, pressures, loads and electrical values are measured. All the results are documented to ensure reliable and rapid traceability.

-20°C version *optional*

Special "C" and "SC" versions are available for ambient temperature up to -20°C, with:

- Anti-freeze feature for evaporator
- Electronic fan speed control
- Crankcase heater (belt type)
- Ventilated and thermostatically controlled heater on the electrical panel.



**Guaranteed
and serviced**

MTA products are designed, built, tested and serviced following the procedures contained in the MTA Quality System. MTA obtained Quality System certification in compliance with ISO 9001 standards from the ICIM Certification Institute in July 1996. Particular attention is dedicated to the servicing network, the training of technicians, territorial coverage and servicing speed and efficiency.



Cooling, drying and caring.